

Topo-Hydrographic Airborne Laser Scanning System with Online Waveform Processing and Full Waveform Recording

RIEGL VQ[®]-880-G

- **designed for combined topographic and hydrographic airborne survey**
- **high accuracy ranging based on echo digitization and online waveform processing with multiple-target capability**
- **multiple-time-around processing for straightforward mission planning and operation**
- **concurrent full waveform output for all measurements for subsequent full waveform analysis**
- **high spatial resolution due to measurement rate of up to 550 kHz and high scanning speed of up to 160 scans/sec**
- **integrated inertial navigation system**
- **additional, fully integrated infrared laser scanner (optional)**
- **integrated digital camera**
- **compact and robust housing compliant with typical hatches in aircrafts and with stabilized platforms**

The **RIEGL[®] VQ-880-G** is a fully integrated airborne laser scanning system for combined hydrographic and topographic surveying. The system is offered with integrated and factory-calibrated high-end GNSS/IMU system and camera. The design allows flexible adaptation of these components to specific application requirements. Complemented by a **RIEGL** data recorder, the **RIEGL VQ-880-G** is a complete LIDAR system to be installed on various platforms in a straightforward way.

The **RIEGL VQ-880-G** carries out laser range measurements for high resolution surveying of underwater topography with a narrow, visible green laser beam, emitted from a powerful pulsed laser source. Subject to clarity, at this particular wavelength the laser beam penetrates water enabling measurement of submerged targets.

The distance measurement is based on the time-of-flight measurement with very short laser pulses and subsequent echo digitization and online waveform processing. To handle target situations with most complex multiple echo signals, beside the online waveform processing the digitized echo waveforms can be stored on the **RIEGL** solid state data recorder for subsequent off-line waveform analysis.

The laser beam is deflected in a circular scan pattern and hits the water surface at a nominally constant incidence angle.

The **VQ-880-G** comprises a high precision inertial measurement sensor for subsequent precise estimation of the instrument's exact location and orientation. A high-resolution digital camera and optionally an additional infrared laser scanner are integrated to supplement the data gained by the green laser scanner.

The rugged internal mechanical structure together with the dust- and splash water proof housing enables long-term operation on airborne platforms.

Typical applications include

- **coastline and shallow water mapping**
- **acquiring base data for flood prevention**
- **measurement for aggradation zones**
- **habitat mapping**
- **surveying for hydraulic engineering**
- **hydro-archeological-surveying**



visit our website
www.riegl.com



RIEGL VQ-880-G Scan Pattern

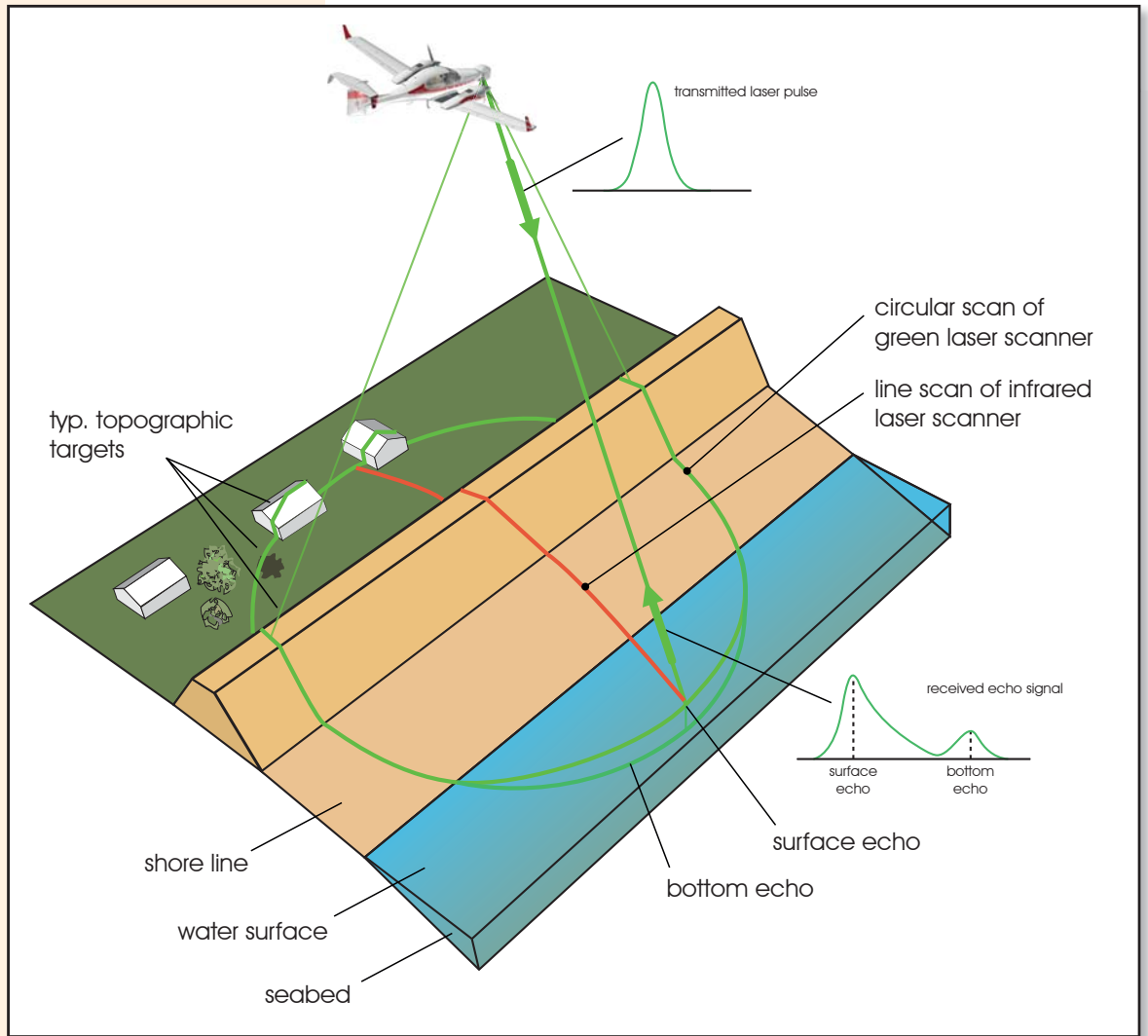

RIEGL VQ-880-G Installation Examples

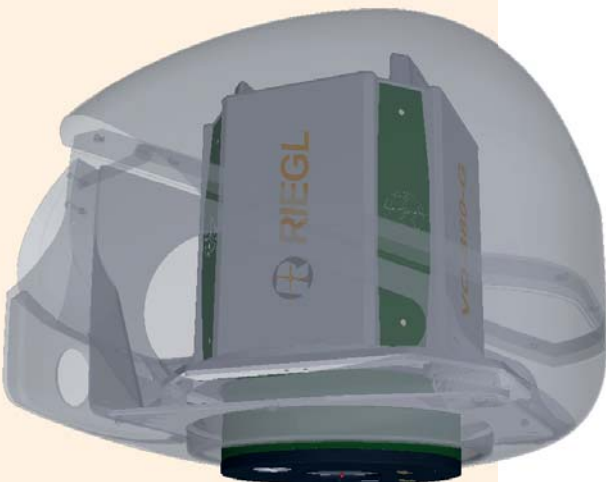

RIEGL VQ-880-G installed in the nose pod of fixed-wing aircraft DA42 MPP



RIEGL VQ-880-G installed on GSM-3000 stabilized platform to be used in a helicopter or fixed-wing aircraft

front view

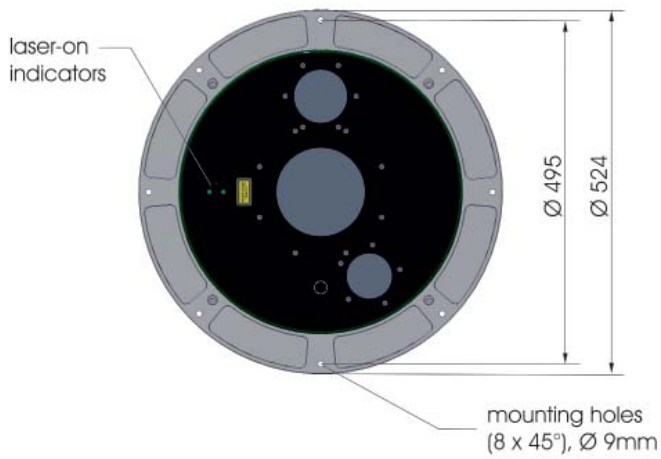

top view

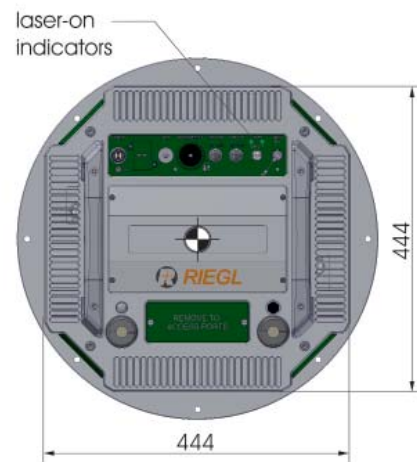

side view



RIEGL VQ-880-G Elements of Function and Operation

aperture for infrared laser scanner or second camera

green laser scanner aperture

aperture for RGB camera



connectors for power supply and data interface

carrying handle (2x)

cooling air outlets

bay for IMU

desiccant cartridge (2x)

mounting flange



Important Note:

The following technical data is relevant for a *RIEGL VQ-880-G* Topo-Hydrographic Airborne Laser Scanning System equipped with an additional Infrared Laser Scanner and is to be seen as a supplement to the Technical Data of the Basic System with Green Laser Scanner.

Laser Product Classification

Laser Class

for *RIEGL VQ-880-G* with additional Infrared Laser Scanner
Class 3B Laser Product according to IEC60825-1:2007

The following clause applies for instruments delivered into the United States: Complies with 21 CFR 1040.10 and 1040.11 except for deviations pursuant to Laser Notice No. 50, dated June 24, 2007.

The Instrument must be used only in combination with the appropriate laser safety box.

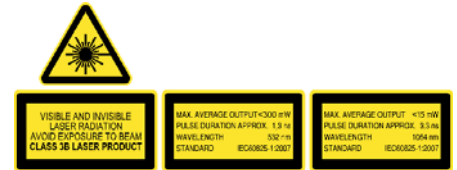

NOHD ¹⁾

1) NOHD ... Nominal Ocular Hazard Distance, based upon MPE according to IEC60825-1:2007, for single pulse condition

100 m ²⁾

2) NOHD for both wavelengths. NOHD of the infrared laser scanner: 34 m

Range Measurement Performance

Measuring Principle

time of flight measurement, echo signal digitization, online waveform processing

Max. Unambiguous Measurement Range ^{3) 4) 5)}

@ Laser Pulse Repetition Rate

natural targets $\rho \geq 20\%$

natural targets $\rho \geq 60\%$

Max. Operating Flight Altitude ⁶⁾

Above Ground Level (AGL)

145 kHz	245 kHz	550 kHz
900 m	700 m	500 m
1500 m	1200 m	850 m
800 m (2600 ft.)	650 m (2130 ft.)	450 m (1480 ft.)

Minimum Range ⁷⁾

Accuracy ^{8) 10)}

Precision ^{9) 10)}

Laser Pulse Repetition Rate ^{11) 12)}

10 m
25 mm
25 mm
up to 550 kHz

Max. Effective Measurement Rate ^{6) 12)}

45 000 meas./sec (@ 145 kHz PRR & 40° FOV)
79 000 meas./sec (@ 245 kHz PRR 40° FOV)
177 200 meas./sec (@ 550 kHz PRR & 40° FOV)

Echo Signal Intensity

Number of Targets per Pulse

Laser Wavelength

Laser Beam Divergence

Laser Beam Footprint (Gaussian Beam Definition)

for each echo signal, high-resolution 16 bit intensity information is provided practically unlimited (details on request)
1.064 nm (near infrared)
0.2 mrad ¹³⁾
22 mm @ 100 m, 105 mm @ 500 m, 200 mm @ 1000 m

Scanner Performance

Scanning Mechanism / Scan Pattern

Field of View (selectable)

Scan Speed (selectable)

Angular Step Width $\Delta \theta$ (selectable)

between consecutive laser shots

Angle Measurement Resolution

rotating polygon mirror / curved parallel lines
 $\pm 20^\circ = 40^\circ$
10 - 200 scans/sec
 $0.002^\circ \leq \Delta \theta \leq 0.045^\circ$

better 0.001° (3.6 arcsec)

General Technical Data ¹⁴⁾

Additional Power Consumption

Additional Weight

typ. 30 W
approx. 3 kg

- 3) The following conditions are assumed: target larger than the footprint of the laser beam, average ambient brightness, visibility 23 km, perpendicular angle of incidence.
- 4) In bright sunlight, the operational range may be considerably shorter and the operational flight altitude may be considerably lower than under an overcast sky.
- 5) Ambiguity to be resolved by post-processing with RIMTA ALS software.
- 6) Reflectivity $\rho \geq 20\%$, 20° FOV, additional roll angle $\pm 5^\circ$
- 7) Limitations for range measurement capability does not consider laser safety.

- 8) Accuracy is the degree of conformity of a measured quantity to its actual (true) value.
- 9) Precision, also called reproducibility or repeatability, is the degree to which further measurements show the same result.
- 10) One sigma @ 150m range under RIEGL test conditions.
- 11) Rounded values.
- 12) User selectable.
- 13) Measured at the 1/e² points. 0.20 mrad corresponds to an increase of 20 cm of beam diameter per 1000 m distance.
- 14) Values to be added to the values given for the standard system with green laser scanner.

Integrated Digital Camera ¹⁾

RGB Camera

Sensor Resolution
Sensor Dimensions (diagonal)
Focal Length of Camera Lens
Field of View (FOV)
Interface

29 MPixel
43 mm (full format)
50 mm
approx. 40° x 27°
GigE

Data Interfaces

Configuration
Scan Data Output

GNSS Interface ²⁾

LAN 10/100/1 000 Mbit/sec
LAN 10/100/1 000 Mbit/sec,
High Speed Serial Dual Glass Fiber Link to RIEGL Data Recorder
Serial RS232 interface for data string with GNSS-time information,
TTL input for 1 PPS synchronization pulse

General Technical Data

Power Supply Input Voltage
Power Consumption

18 - 32 V DC
typ. 300 W (without IMU/GNSS/camera)
typ. 360 W (with IMU/GNSS/camera) ³⁾
max. 400 W

Main Dimensions (LxWxH)
Weight

444 x 444 x 695 mm, mounting flange diameter 524 mm
approx. 62 kg (with IMU/GNSS/camera)
approx. 65 kg (with IMU/GNSS/camera and optional infrared laser scanner)
non condensing
IP54, dust and splash-proof

Humidity
Protection Class Scan Head
Max. Flight Altitude ⁴⁾

16 500 ft (5 000 m) above Mean Sea Level (MSL)
18 000 ft (5 500 m) above MSL

operating
not operating)
Temperature Range
operation / storage

0°C up to +40°C / -10°C up to +50°C

1) The camera configuration of the RIEGL VQ-880-G Laser Scanning System can be modified to the customer's requirements.

2) to be used for external GNSS receiver
3) @ 20°C ambient temperature, 100 kHz PRR, 100 scans/sec
4) For standard atmospheric conditions: 1013 mbar, +15°C at sea level



RIEGL Laser Measurement Systems GmbH
Riedenburgstraße 48
3580 Horn, Austria
Phone: +43 2982 4211 | Fax: +43 2982 4210
office@riegl.co.at
www.riegl.com

RIEGL USA Inc.
Orlando, Florida | info@rieglusa.com | www.rieglusa.com
RIEGL Japan Ltd.
Tokyo, Japan | info@riegl-japan.co.jp | www.riegl-japan.co.jp
RIEGL China Ltd.
Beijing, China | info@riegl.cn | www.riegl.cn

www.riegl.com